

Draft Ver.1

Understanding the forgotten world of analog film sound workflow to improve sound preservation and restoration

By Nicholas Bergh

While the vast majority of picture work in the analog era relies on using edited camera original footage, the audio in the film is more like an elaborate picture effects shot with multiple image layers composited together. Furthermore, this compositing of sounds was standard by the early 1930s and it was soon uncommon to have any non-composited audio in a feature film. Similar to analog picture compositing, each time layers are added together and copied, there is a significant reduction in quality. The history of the film sound technique and technology is largely centered around this compositing process and improving the fidelity and art of the steps involved.

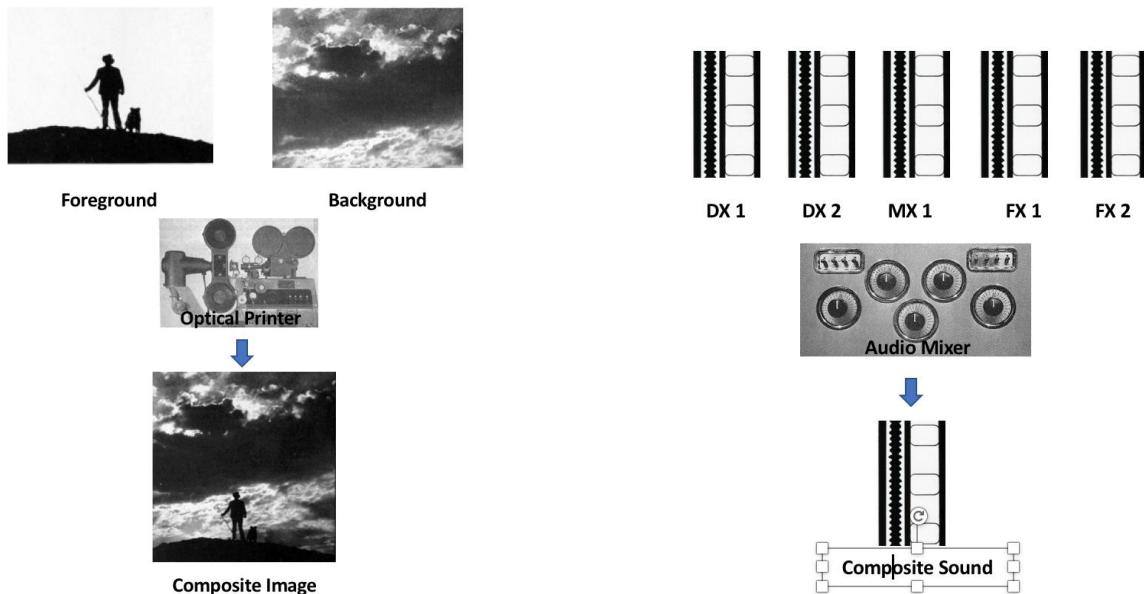

Film sound also differs from picture in that there are typically multiple versions of separately composited audio for a single picture. First of all, there are often multiple language dubs as well as the M&E tracks to make these dubs. Secondly, as theatrical audio systems became varied, there were also different versions for the various sound systems. For example, by the mid 1950s it was already possible for larger studio films to have 6-track stereo, 4-track stereo, and mono versions of the same film. Unlike picture reductions or blow-ups for different frame sizes, the audio was typically re-composited (re-mixed) separately for each of these versions.

As a result of both the multiple steps of the sound compositing process and the multiple unique final audio versions, the number of physical audio elements related to the final release can outnumber original picture elements by over 10 to 1. Making sense of these elements now is further complicated by poor original identification and by different terminology used during different decades or by different studios.

Luckily, the basic principles of film sound workflow are nearly unchanged since the first talkies in the 1920s. One can think of it somewhat like the later evolution of the automobile. A 1990s car is significantly different from a 1920s car, but the core components such as the transmission, engine, and differential are essentially unchanged in function. Once one understands the underlying components of the film sound technique devised in the 1920s, the subsequent decades simply follow with more tracks, improved sound carriers, refined craft, and more likelihood that the elements still exist today.

The Western Electric sound systems and blueprint of motion picture sound workflow

Academic histories of film sound can be confusing and misleading to modern archivists and sound technicians since they typically include short-lived experimental systems, various sound system trade names, and are overlaid with commercial studio histories. However, to get to the technical history of what is actually sitting in archives and film vaults today, one can simply jump through all of this and understand that modern film sound workflow and history came primarily from AT&T and their manufacturing arm, Western Electric.

Although Western Electric quickly had RCA as a fierce competitor, it is rarely understood that RCA was given all of the Western Electric system schematics, research, and instructions because of a patent sharing agreement between AT&T and General Electric in 1920. As a result, the initial RCA system was simply a direct copy of the Western Electric system except for the optical recorder designed in-house at General Electric. Similarly, Movitone was also Western Electric except for the optical recorder at the very end of the recording chain.

RCA and the major film studios all added significant improvements to the original system, but the core system comes from one place. Going back to the car analogy, these companies came up with inventive new versions of say the transmission or differential in the car, but the function within the system remained the same. Similarly, the microphone or modulators may be different in the recording chain, but core architecture from impedances, gain structure, synchronization, rack standards, wiring standards, etc. all came from the initial AT&T work.

AT&T engineers began research on synchronous electrical film sound recording in 1919 and by 1924 had a robust working system that was being demonstrated to studios. Initially they demonstrated the system via synchronous disc recording, but their optical sound recording technology using the same system followed shortly after. This system was first adopted and marketed by Warner Brothers as “Vitaphone,” but was the exact same system used at other studios such as Paramount and MGM simply under the name “Western Electric Sound System.”

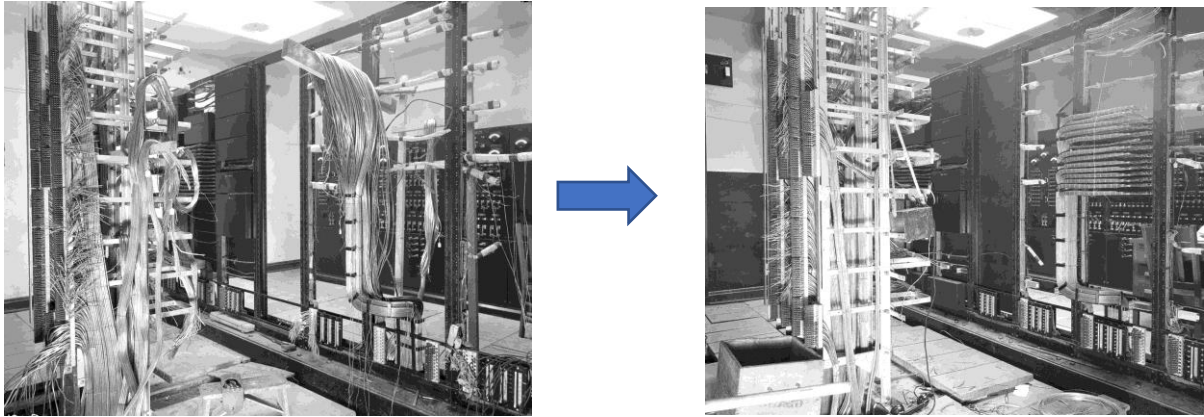

Images showing two steps of the wiring guts of a *small* Western Electric film sound installation to help understand the sophistication from day one. The studio installations were configured like telephone exchanges in infrastructure with thousands of miles of cable running between the various audio rooms. Some of the lead-covered “trunk” audio lines laid in the 1920s and early 1930s to connect audio buildings are still present at major studios today.

It is difficult to overstate how advanced and carefully engineered this first Western Electric film sound system was. In some ways it is not surprising since AT&T was dealing with electrical audio transmission and filtering over decades for telephone work, and conducting R&D specifically on electrical recording and film sound for nearly a decade by 1928. It is also important to be aware that similar to AT&T telephone systems, the equipment was all leased and profits were derived from use of the equipment (every foot of released film). As a result, the equipment could be made to a quality standard that would be impractical for selling it. What survives of this early equipment is typically still working well, almost 100 years later.

Interlock motor and audio mixing

There are two central components of the Western Electric system that are critical for understanding film sound workflow through the decades. The first is the interlock motor system and the second is audio mixing.

The interlock motor system was not invented for sound work, but was put to work in the Western Electric sound system in a very clever and useful way. The original uses for the system were for applications like controlling gun turrets on WWI battleships and for the motorized locks in canals. Explained simply, when the shaft on the master motor is turned, any number of “slave” motors connected to it will turn the same way. For example, if the master turns exactly 10 rotations, each slave motor will also turn 10 rotations. To drive this master motor (the interlock distributor), a special speed-controlled motor is used to insure exactly 24 frames at the machines.

Any number of motors can be driven from the master, and one of these motors is attached to the film camera. When the sound equipment motor turns 10 rotations, the camera motor also

turns 10 rotations and the two are in perfect synchronization. It is often forgotten that during the Golden Era of Hollywood, the camera operator never started their own camera for a sound take. It was always the sound department who started the picture camera since they were in charge of the interlock distributor.

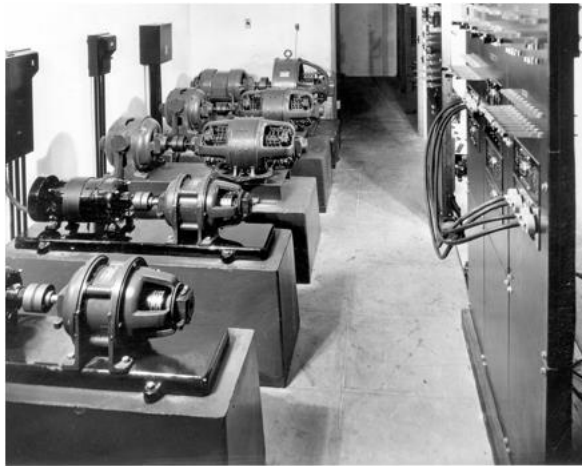

1928 Interlock generators and patch panel



1950s-1970s Interlock generators and patch panel

Below is an original 1920s schematic diagram from Western Electric showing the basic layout of the motor interlock systems connecting the sound recording room, film cameras, and motor room. Six wires are used for each motor as shown. 3-phase 220v mains power for the primary motor windings, and another 3-phase 220v input for the control windings from the interlock distributor. The exact number of machines that could be synchronized together from the same distributor varied somewhat by the current draw of each motor, but it was well beyond the number of motors used in practice. Essentially dozens of motors could be run from the same distributor.

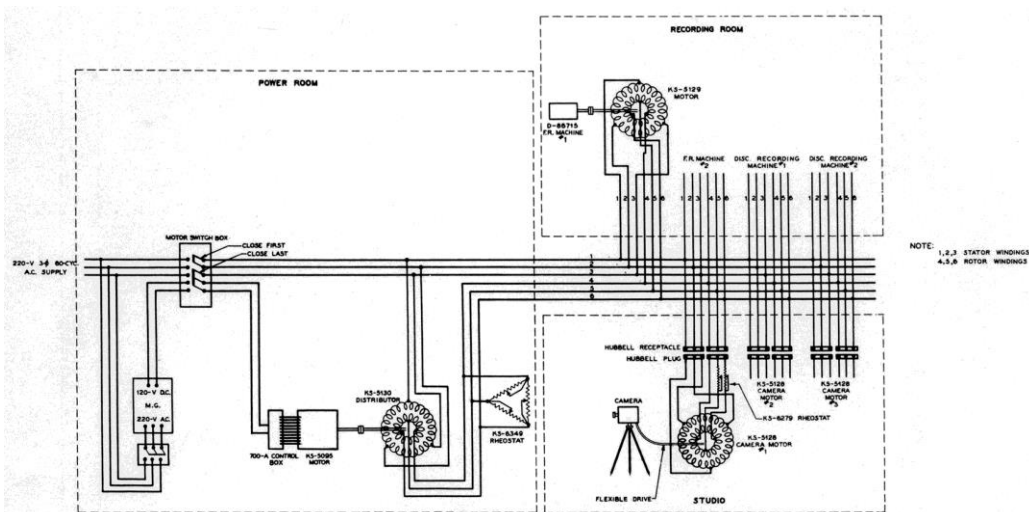

1920s Western Electric diagram of interlock motor system. Photo: Endpoint museum collection

If one looks up the history of multi-track recording, almost all references will say the process originated with Les Paul in the 1940s. However, the ability to do multi-track recording was standard to the Western Electric system from the 1920s (something Les Paul would have seen as a session musician at MGM in the 1930s). The music industry was barely using three tracks in the 1950s, while the film industry could essentially use an infinite number of tracks by the late 1920s. This is because any number of single-track sound machines could run as a single machine through the synchronous motor control of the interlock distributor.

In practice, the number of tracks was limited primarily by the noise of the recording format and the complication of controlling too many tracks. As the media became quieter, more tracks could be added together without excessive noise. For example, it was not until optical noise reduction was developed in 1931 that mixing could be used more widely with optical sound elements. Before 1931, it was more successful to mix disc recordings, which were quieter.

Since the motors were electrically phase-locked together, the synchronization of the machines themselves was near perfect (within roughly 1/1000 of a film frame). In practice, the synchronization accuracy of the 1920s system was dictated by the four perforations per frame of the 35mm film and intentional motion filtering in the mechanics. Even at its worst, this typically yielded a remarkable ¼-frame or 1/96th of a second accuracy. This is far better than what is typically experienced by consumers today due to mismatched hardware latency.

Once multiple tracks of audio are running in sync together, all one needs is a way to electrically combine the signals and adjust their relative levels. Audio mixing panels were used in the Western Electric system originally for mixing together microphones during an initial recording, but were quickly also used for re-recording the sounds from various tracks that were recorded at different times. The mixer panels were modular in groups of three inputs and could be added together to obtain any number of desired inputs. The standard Western Electric configuration in the late 1920s was a six or nine input mixer with as many as two or three group outputs (for recording multiple tracks at the same time). Early multi-track recording was used for applications like recording a vocal or soloist separately from the orchestra, or for near and far mic placements so the amount of room tone could be controlled in the final mix.

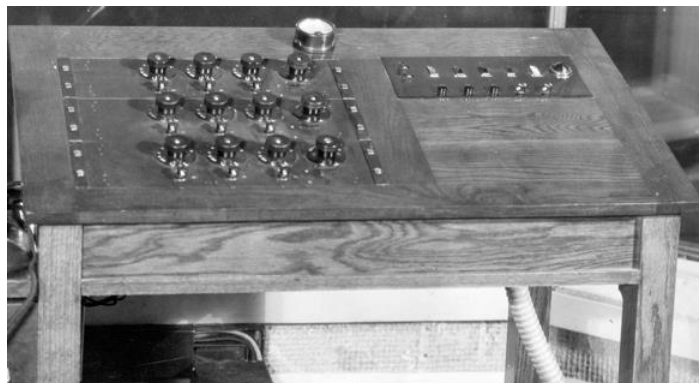
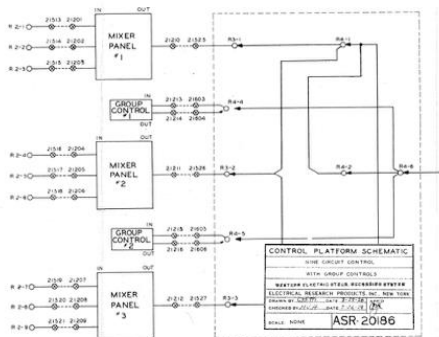

1928 Modular Western Electric mixer capable of any number of inputs and groups by adding panels as desired. By March 1928 they were already specifying nine inputs and two group outputs. The version on right is similar but uses three output groups (right-most knob on each of the panels). Photo: Endpoint museum collection

The sound equipment attached to the interlock distributors evolved over the decades to improve sound quality and increase track density, but the core system remained the same. The interlock distributors were eventually phased out by the use of bi-phase/stepping motors starting in the late 1970s, but some of the 1920s interlock systems continued to be used into 1990s for some applications. Vintage machine room photos are unfortunately not common since it was not a glamorous part of the studio, but machine room images are an important way to help understand how little changed fundamentally through the decades. The below photos show the evolution of the original machine rooms from the 1920s to the final analog machine rooms of the late 1990s which were responsible for the last analog blockbuster film mixes such as TITANIC (1997).

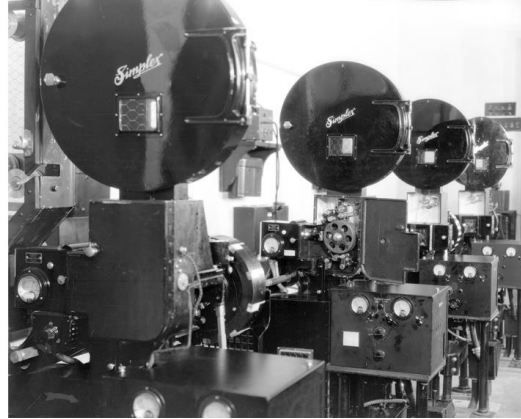

Examples of the earliest re-recording installations in the late 1920s and early 1930s. Left image shows 7 tracks of discs and one track of optical. Right image shows 4-tracks of optical dubbers. Additional machines are out of view in this image. Photos: Endpoint museum collection.

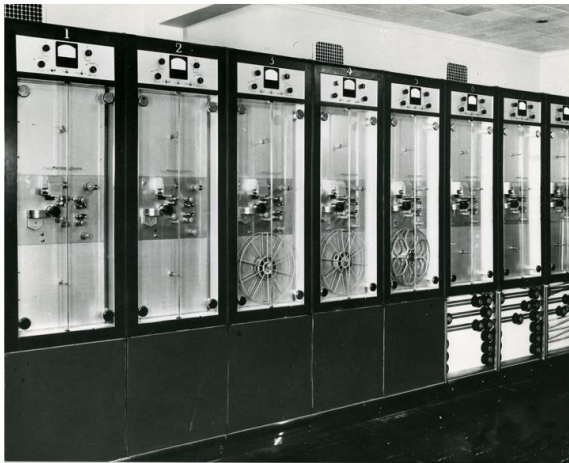

8-tracks of optical dubbers in late 1940s. The three right machines show loop cabinets for background effects such as rain. The right image shows how optical dubbers were simply updated with mag heads/electronics and continued to be used as 3-track mag dubbers. Optical dubbers like these, and even earlier machines from the late 1930s were still being used as mag machines in the 1970s due to the quality of their original construction. Photos: Endpoint museum collection.



Left: Todd-AO machine room showing the 6-track Westrex mag machines installed in 1950s for 6-track stereo and capable of a total of over 100 tracks. Right: Todd-AO machine room in 1994 shown with Magna-tech dual mag dubbers. Dual-dubbers increased the max track count to around 132. In practice, a mix of single-stripe, 3-track, and 6-track mag units were used so actual track count used would never be that high and was essentially limited by the number of inputs on the re-recording console. Left Photo: unknown, Right Photo: Thomas Hauerslev

35mm sound element workflow in the analog era ~1928 to ~2000

Nicholas Bergh, Endpoint Audio Labs

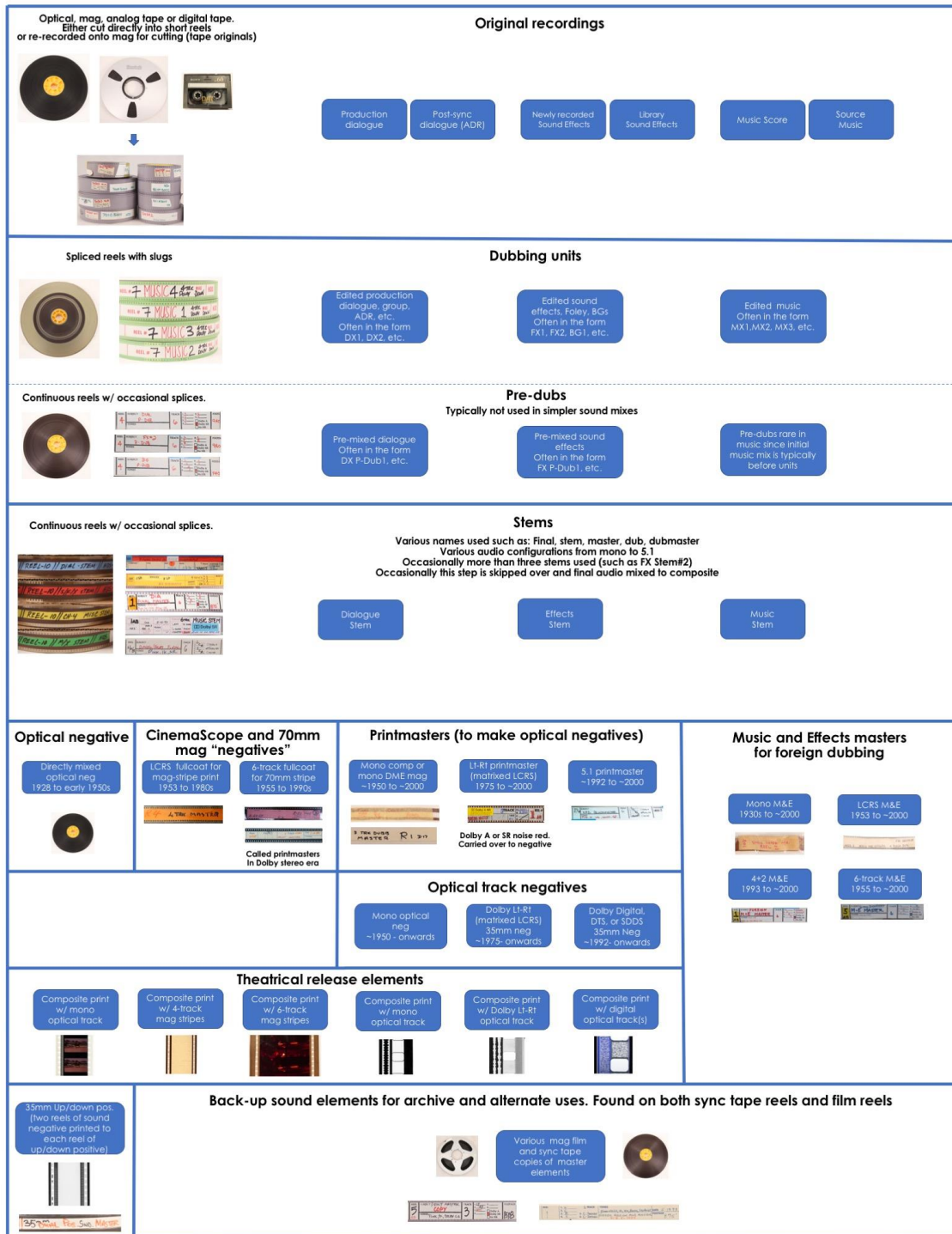

Detailed look at workflow and the creation of physical sound elements

Once one understands the underlying mechanics of analog film sound, it is possible to better understand the steps within the workflow and the elements that are created/utilized at each step. Understanding this workflow helps make sense of the elements in archives today and how they can be prioritized in preservation and restoration. The basic categories of elements with example images are shown on the preceding page, and this section will describe the workflow and elements in more detail. Typically, the most important and useful elements today are the final master elements as well as the original source elements which have the greatest fidelity (equivalent to the camera negative in picture work).

Even though almost all films went through these various steps, the more recent the film the more likely the elements in the intermediate steps would have been saved. For example, a 1980s film may still have a couple of pallets worth of film sound elements comprising nearly all steps of the audio workflow. On the other hand, one may be lucky if any master elements still survive for a film from the early 1930s.

Step 1: Source recordings

At the very beginning of the film sound process is the recording of raw source material. This includes sync dialogue during filming, music score, dedicated effects, etc. Also, at this stage is the occasional gathering of non-sync commercial music that will be converted to sync formats before mixing. Equipment for sound recording improved significantly in sound quality and size over the decades, but the basic process is similar regardless of format. The biggest changes came with the use of portable tape recorders, especially in the 1960s, and this will be addressed after the earlier formats.

Disc and optical recording

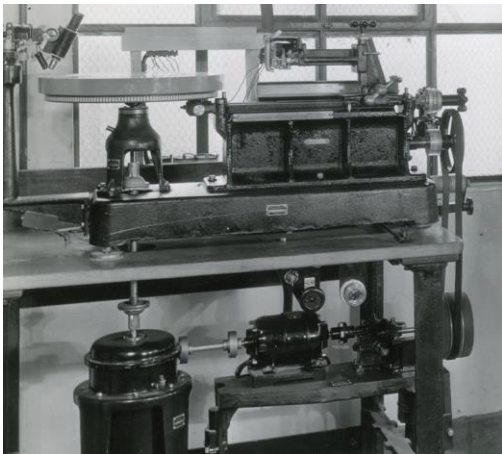

1920s synchronous lathe used for recording soundtrack discs. These machines continued to be used for decades after converting to instantaneous lacquer discs in the mid 1930s. Photo: Endpoint museum collection

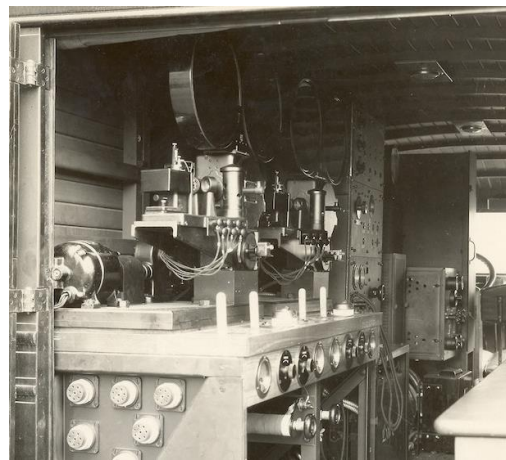

Example of an optical recording system in a sound truck that could be used for field recording. These trucks were also commonly attached to a sound stage or used on a backlot. Photo: Endpoint museum collection



Example of an original Vitaphone source recording of train effects used as a mix unit. This element would be placed on one of the turntables shown in the earlier disc machine room image.



Example of the optical source elements. Typically recorded on a 1000ft roll and then cut into takes.

For later sound elements like magnetic film, tape, and digital formats, the media in the recording machine is the final media used for playback. However, this is not the case with optical recording and early disc recording so it is important to better understand the intermediate elements as well.

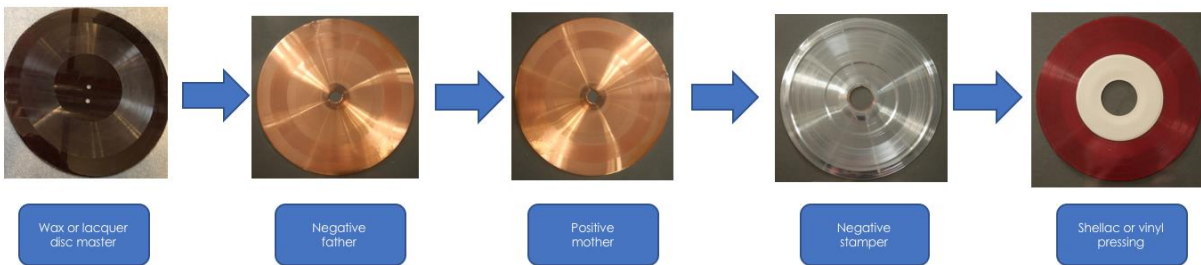

Example of the “3-step” disc replication still used today. Fathers and mothers can be copper or nickel-plated copper.

The final shellac recordings used for theaters or internal dubbing uses could only be created by a multi-step process. The original recording format was a thick wax blank that could not be played back without immediate damage. Often two recording lathes were used in tandem so one disc could be previewed (and damaged) while the untouched disc could be used for replicating the master. The master wax would then be electroplated to create a metal negative of the grooves that could be used to stamp out many positive discs. Since these metal parts wore out from the significant stress of pressing the record, a “3-step” pressing process was typically utilized so that many duplicate metal stampers could be made. In this workflow there is a negative “father” created from the original wax, then a positive “mother” made from the father, then a negative stamper from the mother. Once a stamper wore out, it could be remade from the mother, and if the mother became worn or damaged, a new one could be made from the father. With this workflow, over 100,000 records could be made from a single wax master. This same 3-step process is still used today to make modern vinyl LP records from lacquer masters.

In the mid-1930s, lacquer-coated aluminum discs became available and eliminated the need for pressing records when only a single or a few records were needed. Lacquer discs were used widely by the film studios for such applications as playbacks during filming of musicals, for checking optical takes, effects recordings, and actor test recordings.



Example of instantaneous studio lacquer disc used internally from mid-1930s into the 1970s.

Negative and positive optical sound tracks

Similar to a camera negative, the original optical sound negative created in an optical recording machine is printed to positive film before it was used in a theater or for mixing before magnetic film. The process is more complicated for sound than it is for picture, though, and the relationship between negative and positive sound is often severely misunderstood. This can be highly problematic today when sound negatives are attempted to be used directly in restorations like the picture negative.

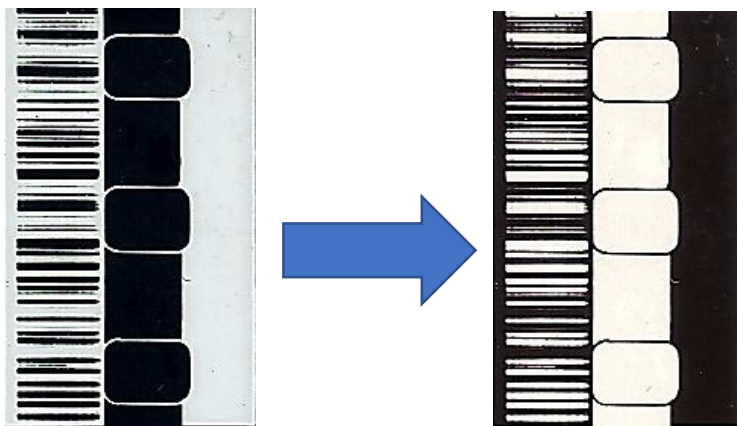

Optical sound is unique in that it is extremely helpful to intentionally “distort” the negative during recording in a variety of ways so that the positive sounds as good as possible. In other words, the negative was almost never intended to be used on its own without printing. Only specialized direct-positives were intended to be used without printing. One way the sound is distorted is by

manipulating the amount of light present between loud and soft areas of audio. By intentionally reducing the amount of light passing through the film in a quiet section of a positive, it was possible to reduce the amount of grain noise heard. In loud sections, the noise is masked by program audio so the full amount of light is let through to enable the most output level as possible. This process is called optical noise reduction and was used on almost all optical tracks starting in 1931 (Western Electric “noiseless recording”).

Today when people are searching for film sound elements, it is common to interpret the presence of a sound track negative similar to the original picture negative. However, a track negative cannot be simply “flipped” to positive like an image element since the intentional distortion will not work itself out naturally until printed. Various modern technologies are available to simulate the process of printing, but only rarely can the same quality be achieved since they are simulations and not a raw transfer of the element.

Magnetic recordings of source materials

Magnetic film started to be used by the late 1940s, but did not start to phase out optical production recording until the early 1950s. One of the challenges compared to optical was that the modulation could not be seen on the film so it was much more difficult to edit. One had to carefully listen for the exact edit point rather than simply seeing the obvious edit point in the modulation.

Magnetic recording did not change source recording significantly from a workflow perspective since most early magnetic recording machines were simply converted optical machines. Even dedicated mag film machines were still quite bulky and required trucks for remote use. However, magnetic sound finally allowed the direct monitoring and playback of the recorded track, which was not possible with optical sound. It also offered the ability to do multi-track recording on a single element. This could be utilized for multiple mono tracks or for stereo recordings of the same source. Early 35mm mag was typically single-track or 3-track, but within a few years 4-track and 6-track were also available. Portable stereo recording mag machines were being used by the early 1950s for Cinerama and CinemaScope productions.

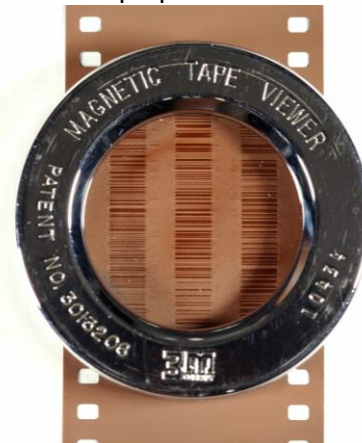

Example of remote production mag recording. Still often used within a sound truck like the earlier optical recording systems. Mag recording within the confines of a studio simply used the large mag machines shown in the previous section.

Production workflow did change significantly with the availability of synchronous magnetic tape recorders starting in the 1950s from companies such as Rangertone, Perfectone, and Nagra. While early machines like Rangertone were still quite bulky, the small battery powered systems from Perfectone and Nagra allowed the recording system to easily follow an actor and allowed smaller sound crews. By the early 1960s, Nagra recorders had become standard for location recording. Tape synchronizers were also fitted to larger multi-track studio tape machines and synchronous tapes were used widely for music recording. Additionally, these larger studio tape machines were typically used at studios to play back the tapes recorded in the field.



Early 1970s location recording with battery-powered Nagra tape recorder. Photo: Nagra Audio

All magnetic tape systems utilized a very different form of synchronization with picture than the earlier optical and mag machines using interlock motors. The synchronous tape systems do not actually run in sync with the camera. Instead, they save a record of the camera sync in the form of the motor line frequency embedded along with the audio. The main issue is simply storing this 60Hz or 50Hz reference on the tape with the audio in a way that does not add hum or other problems to the program material.

Many approaches were used over the years to record the sync signal on the tape, but the inherent process is still the same regardless of how the tone is recorded on the tape. In most cases, the tone is “hidden” from standard audio heads and cannot be extracted properly without the correct head or hardware configuration. Some of the formats were more successful than others and were therefore used widely. For example, the Nagra neo-pilot format for ¼” tape was very robust and used widely around the world.



Rangertone
(shown on 1/2" 3-track)

Neo-pilot
(shown without audio)

Center-track time code
(note repeating timecode
"word" in center)

Example: of the "hidden" sync signal on tape formats. Although the speed will be in perfect synchronization, the tape cannot be started in sync except when using timecode. Even with timecode, the speed of the tape machine is governed by the 60Hz signal imbedded within the timecode "word."

The problem with using synchronous analog tape is that it cannot be edited in sync with picture and it cannot start in sync (except for later timecode tapes). As a result, tapes are typically an intermediate format that must be transferred to spocketed media before they can be used. As a result, they typically suffer a second analog generation that diminishes sound quality. Production dialogue recordings on tape would typically get transferred to single-stripe mag film, while music tapes were transferred to higher-quality fullcoat mag film.



Example of 1980s machine room recording sync tape dailies and source music tapes to mag film. Typically, 35mm mag film was used for films shot on 35mm film while 16mm magnetic film for used for films shot on 16mm film. Source unknown.

Step 2: Edit source recording into “units” to match picture edit

The optical and mag sources recorded onto full reels would eventually be cut up into takes, scenes, or cues. These small rolls would then be assembled through the use of synchronizers and Moviolas into reels to match the supplied workprint from the picture editing department.

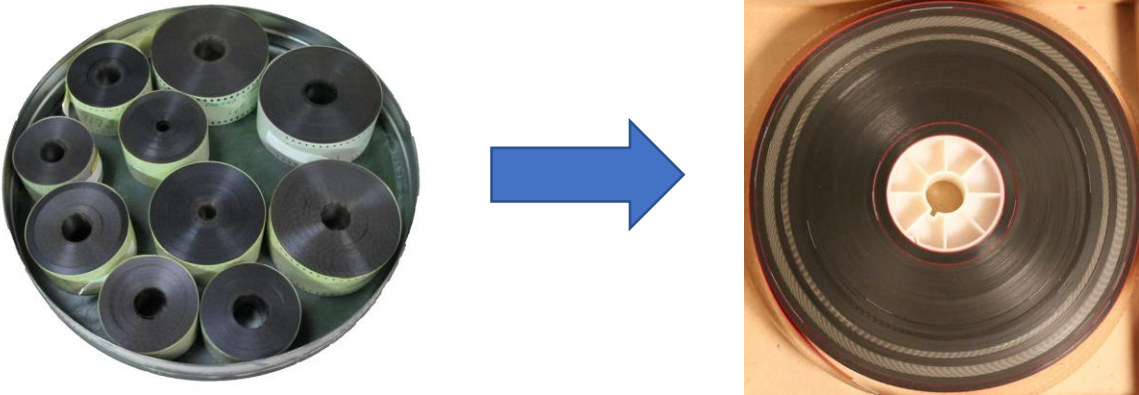

To make up the blank area between audio, they would typically use rejected sound takes or picture film as leader (reversed so there would be no sound). Even in the mag era it was common to use junk picture film for “slug” between sections of audio. This type of mixing of film stocks is rare in any other sources so units can usually be quickly identified by looking at the side of a reel.



Sound editing at RKO in 1937 showing synchronizer on right and Moviola editor on left. This version allowed three tracks of audio to be synchronized with a work print. Photo: Bison Archive

Step 3: “Pre-dub” or pre-mix some source elements that would result in too many tracks or unnecessary complication in the final mix

The pre-dub stage is most commonly found in later large-scale studio films where many dozen tracks are needed. However, it was occasionally used early on for applications like a sequence in a musical where multiple instruments, vocals, and tap had to be mixed together. The primary disadvantage of a pre-dub is the sound quality loss of an extra analog generation so it was only used when needed. For a self-contained music section, it was possible to edit directly into the mixed track to avoid the extra generation. It was easier to utilize pre-dubs in later decades once there were quieter magnetic film stocks and Dolby noise reduction became available.

Pre-dubs can also show up in independent films where a low budget studio was used with limited equipment. For example, if eight 16mm tracks are needed, but only five 16mm mag dubbers are available, then a pre-mix was needed to reduce the number of tracks in the final mix. One famous independent film that used pre-mixing was NIGHT OF THE LIVING DEAD (1968) due to the limited re-recording facilities in Pittsburg at the time.

Pre-dub elements typically differ in appearance from units in that they are usually continuous media without any slugs and with only occasional splices.

Step 4: Final re-recording mix

Once units were edited and any necessary pre-dubs were mixed, the final re-recording was started. Often some reels began the mix process while other reels were still being edited. To understand analog re-recording, it is important to be aware that for most of the history of analog film sound, the machines did not back up and there was no option to make a fix within a recorded reel. As a result, re-recording was handled like a live performance over a full reel at once. After a re-recording pass, all the units had to be re-wound and re-laced before another pass could be attempted. Usually multiple practice passes were conducted before the final recording. Depending on the complexity of the mix, between one and three mixers were used at the re-recording console.

If something did go wrong during re-recording, the entire reel was re-mix, and if needed, multiple takes of a reel could be spliced together. In the later years of mag film re-recording it did become possible to reverse all of the dubbers at once in sync, as well as “punch-in” to make a fix into an already recorded mag. It was still typically necessary to confirm the fix did not create a click or other obvious anomaly.

DUBBING SHEET						
PRODUCTION: SIX MONTHS		REEL: 4		LENGTH: 930 FT.		
	Dial.	Music A.	Music B.	FX1.	FX2.	Loop
0	Pit	Comm.	4M1		Cage	
	Ambulance					Ambulance bell
100						
			Mix to	4M2		
200	London	Comm.	Street organ		Traffic	Single bus Single car Horns Car
300						
	Theatre	Dial. Play			Laughter	
400	Coast	Comm.	Fade in 4M3		Wind	Applause Hammer
500				Trumpet solo		Plane Bang
600	Battle	Shouts	Mix to	4M4	Guns Guns Plane	Big battle Bombers
700						
			Big gun			
800	L.S Fields	Comm.	4M5		Tractor	Distant planes
900				Birds	General farm	

Example of a 1940s re-recording log sheet for a small film using six tracks. Last track is a continuous effects loop



MGM 20-input re-recording console used for most mono films at MGM from early 1940s to 1970s. Only patched EQs on left and right side of console were present.

Another point to be aware of in analog re-recording is that there were relatively limited tools available to the mixer compared to modern ProTools mixing. The primary tool of the re-recording mixer was the level control on each track, and the second most common tool was equalization. Typically, there was not equalization present on each channel and an EQ was only patched-in as needed. This is why in the early decades it was critical for the original source recordings to be as quiet and as close in desired tonality as possible. An additional tool available in analog re-recording was analog reverb (patched onto a track or group). Only in the final decades of analog mixing did channel equalization and production noise reduction tools become standard. The additional change that occurred at the end of the analog re-recording era was the addition of automation to consoles so that fader moves could be remembered and each mix “take” could utilize the work of the previous take.

The primary goal of re-recording was to create the final composite track used to make prints necessary for theatrical distribution. In the first few years of film sound this could be a final wax disc master for Vitaphone releases, but very quickly the optical track negative became the final mix format. With the advent of magnetic releases such as CinemaScope and 70mm Todd-AO in the 1950s, the final mix was recorded to a 4-track or 6-track fullcoat mag. This element was also commonly referred to as a “negative” on the cans and in inventory since it was used for creating the audio on the mag-stripes of the release prints. Once Dolby started to become involved in Dolby Stereo releases in the late 1970s, the term “printmaster” became fairly universal for the final composite mix and printmaster is still the standard term today.

Stems

Along with the final composite mix, it was also helpful to save final mixed tracks of isolated dialogue, isolated music, and isolated effects. These were called DMEs for short (or ABCs at MGM because of the buss markings on the MGM re-recording console). They were most commonly used as the source for foreign language dubs since they provided isolated M&E tracks plus a dialogue guide. Some studios like Columbia would even use reflective tape and triggers to extract production effects from the dialogue track during M&E use.

Mono DME stems could have been made as early as the late 1920s via the 3-group mixing consoles along with three interlocked optical recorders. However, optical recorders were very expensive and challenging to use. Therefore, tying up three optical recorders to create DMEs was a significant investment and would create unwanted delays in the mix. DMEs were occasionally made in the optical era in this way, but likely not until the 1940s. It was not until 3-track mag became available in the late 1940s/early 1950s, that DMEs could be recorded to a single piece of film and the DME process became much more practical.

It eventually became fairly standard to make the final re-recording mix to a 3-track mono DME mag instead of a mono composite track. This allowed access to the discrete mixed tracks as well as the composite by simply summing the three tracks together.

Stems became more complicated for stereo films since there were not enough tracks to record stereo stems onto a single mag. For stereo films, there was typically a discrete composite mag mix and then stems on additional mags. Usually this would be three separate mags to cover the dialogue, music, and effects stems, but occasionally all three were fit on two mags to reduce the cost of film stock. For example, it was possible to get DME LCRS stems on two 6-track mags instead of using three 4-track mags.

In theory, audio stems should match the final composite mix when the stems are summed together. However, for both mono films and stereo films, it was possible to treat the DME stems as sort of a pre-mix and do final mix adjustment before summing to a composite track. As a result, one cannot always trust that stems are representative of what was heard in the theater. They should always be checked against a release print to confirm if any changes were made. Additionally, when DMEs were created primarily for M&E work, they were often created before the final mix was finished so that language dubs could be finished before a release date. This is not uncommon with M&Es and so it can also be good to check M&Es against the final master to insure there were no late mix changes that were not incorporated into the M&E track. Dates on the mags can be helpful to see when an M&E was made compared to the composite. If the M&E was made after the final mix, it is usually safe to use without checking.

M&E Creation

For early films, an M&E was typically just a combined track made from the music and effects units of the final mix. However, this would be missing many effects and backgrounds that were captured during production on the dialogue track. Later it was more common for a dedicated

M&E mix to create a “filled” M&E that contained at least any major missing effects from the dialogue track. Over the decades, the completeness of fill on the M&E increased as the desire for higher quality foreign language versions increased. In later years, M&Es are more commonly found as “fully-filled,” although the quality of the fill work can still vary widely. Often there are as many M&E versions present as audio versions of the film. For example, if there were 6-track, 4-track, and mono mixes of a film, there are often three corresponding M&Es.

Backup audio elements

Once a mix was complete, it was also common to create additional back-up copies. A copy of a master mag was often called an “x-copy” or a 3-to-3, 6-to-6, etc. To save money, copies were also made to sync analog tapes just like what was used for sync source recordings. Although it was much more difficult to make an optical track from a tape than a mag, it was possible if required.

During the 1960s and 1970s, it was also not uncommon to save money for the master mag to be degaussed and reused after creating the track negative. Usually a tape backup was made before this and the tape became the only remaining magnetic source. Sync tape sources are often very important elements for preservation and restoration because of this practice. Since people are typically looking for film sources for a film restoration, they can unfortunately get overlooked. It is also not uncommon that once vintage films became more important for re-release in the video era, an archival mag was made of the tape copy. It is unfortunately very common for the new mag to be used for restoration instead of the original tape copy.

Step 5: Release prints

A variety of different theatrical audio release formats were used over the decades, but the standard ones are luckily very few in number. The mono optical track on a composite release print was the most common of all and reigned for many decades. Although many physical variations of mono optical tracks were developed over the years, almost all were intended to be played on standard theatrical equipment. The look of the particular optical track is mostly useful as an additional way to help date the element since some optical tracks were only used during certain years. For example, it is important to be aware of re-recorded track negatives of early films so they are not mistaken as original.

Only a few short-lived mono optical formats such as Perspecta Sound required decoding electronics after the soundhead to extract the intended audio. Usually these specialized formats are mentioned in legacy advertising for a film since it was done for added value, and these ads can be helpful to confirm suspicions. For Perspecta, the presence of low-frequency control tones in the program audio is the key audio identifier. Technical details on short-lived release formats can typically be found in the SMPTE journal when needed.

The 1950s added stereo mag-stripped release prints for CinemaScope and 70mm Todd-AO. Both of these formats became fairly standardized for theatrical use and continued to be used occasionally for later films as well. The original 70mm format was re-worked as Dolby 70mm in the 1970s and utilized the original Left-Center and Right-Center tracks as low-frequency “boom” tracks.

In the late 1970s, Dolby stereo optical became available, followed by Dolby Digital, DTS, and Sony SDDS digital formats in the 1990s. With these later optical release formats, there is almost always a master or non-optical copy still available so it is very rare to need to use these later theatrical sound formats for preservation or restoration.

Transition to digital re-recording workflow

By the 1980s, digital sound recording was often used for commercial music recording and occasionally for film scoring. However, it was not until about 1998-2000 that digital recording replaced mag film for editing and re-recording. Mag tracks offered easier editing and the equipment was tried and true, which was very desirable when say the director or studio executives were present at a mix. Although there was some limited use of DA-88s for re-recording, the first robust digital recorders to take over mag machines were typically the Tascam MMR-8 on the West Coast and the Akai DD8 on the East Coast. They utilized plug-in SCSI hard drives as the recording media and could be synchronized by timecode or even bi-phase like the earlier mag machines.



Example of the early 2000s digital dubbers (Tascam MMR-8) that replaced mag machines. This picture shows 128 tracks plus 16-track of DA-88s. The left side shows a shelf of removable hard drives from this era that were often deleted and reused after a mix. Final delivery was on MO Discs or DA-88s. Any mags in this era are typically archival backups of digital elements. Photo source unknown.

Although ProTools and other digital audio workstations (DAWs) were available at this time, they still did not have the reliability or track counts to be able to be used for large re-recording operations. Some smaller-scale mixes were done on ProTools as early as the late 1990s, but ProTools did not become common for major studio mixes until around 2010. ProTools mixing is

now nearly universal from the largest mixes to the smallest. Multiple ProTools systems/computers can be linked together and it is not uncommon for a big mix to utilize many hundreds of tracks. In many ways, the new era of in-the-box mixing is wildly different than the analog era of re-recording. For example, nearly unlimited equalization and effects can be applied to any track, all moves and effects adjustments are fully automated and stored, track count is nearly unlimited, non-linear moving within the timeline is possible, and routing for delivery versions can be extremely complex.

Conclusion

Due to the large number of audio elements used to create a final soundtrack in the analog era, selecting the best sources for preservation and restoration is often significantly more challenging than for picture preservation. Understanding analog film sound workflow and the look of elements within the workflow can increase the likelihood the best sources are found. The element workflow diagram included can be used as a quick guide for the terminology and types of elements that can be present.